

Task №3
CALCULATION OF NATURAL FREQUENCIES AND STEADY-STATE
OSCILLATIONS
using ANSYS and FlexPDE

Keywords

1. Theory of elasticity – structural analysis
2. 2D problem
3. Modal analysis
4. Harmonic analysis

Part 1. Calculation of natural frequencies for a compound elastic plate

Problem statement

Let us consider a plate in a shape of double T-region. The upper part of the plate is made of steel with the Young's modulus $E=2 \cdot 10^{11}$ (N/m²), Poisson's ratio $\nu=0,29$ and density $\rho=7.8 \cdot 10^3$ (kg/m³). The lower part of the plate is made of copper with the Young's modulus $E=1.2 \cdot 10^{11}$ (N/m²), Poisson's ratio $\nu=0,33$ and density $\rho=8.9 \cdot 10^3$ (kg/m³). Both parts have the shape of T-letter (Fig. 1). The dimensions are $l=0.05$ (m); $b=0.16$ (m), $h=0.02$ (m). Bottom boundary of the plate is rigidly fixed. The objective is to calculate the first four natural frequencies of the plate and plot the corresponding mode shapes. The modal analysis should be performed in assumption of plane stress.

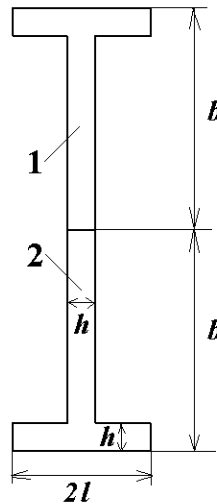

Fig. 1 Scheme of a double-T region

THEORETICAL BACKGFOUND (part 1)

In assumption of plane stress, the displacements of the plate in the region Ω , in the xy -plane are characterized by the displacement vector $\underline{U}=\{U_x, U_y\}=\{U, V\}$, where $U=U(x, y)$, $V=V(x, y)$. The components ε_{xx} , $\varepsilon_{xy} = \varepsilon_{yx}$, ε_{yy} of the strain tensor $\underline{\varepsilon}$ are related to the components of the displacement vector \underline{U} by formulas:

$$S_{xx} = \varepsilon_{xx} = \partial U / \partial x ; S_{yy} = \varepsilon_{yy} = \partial V / \partial y ; \quad (1)$$

$$S_{xy} = \varepsilon_{xy} = (\partial U / \partial y + \partial V / \partial x) / 2$$

The constitutive relations between mechanical stresses and strains in an elastic isotropic medium under plane stress state have the form

$$\begin{aligned} T_{xx} = \sigma_{xx} &= \lambda^* (S_{xx} + S_{yy}) + 2\mu S_{xx} \\ T_{yy} = \sigma_{yy} &= \lambda^* (S_{xx} + S_{yy}) + 2\mu S_{yy} \\ T_{xy} = \sigma_{xy} &= 2\mu S_{xy} \end{aligned} \quad (2)$$

where $\underline{\underline{\sigma}}$ is the stress tensor, σ_{xx} , $\sigma_{xy} = \sigma_{yx}$, σ_{yy} are the components of the stress tensor and

$$\lambda^* = \frac{2\lambda\mu}{\lambda + 2\mu} \quad (3)$$

$$\lambda' = \frac{\nu E}{(1+\nu)(1-2\nu)}, \quad \mu = \frac{E}{2(1+\nu)} \quad (4)$$

In (4) λ' and μ are Lamé's coefficients, E is the Young's modulus, and ν is the Poisson's ratio.

The equilibrium equations for modal analysis have the form

$$\partial T_{xx} / \partial x + \partial T_{xy} / \partial y + \lambda \rho u = 0 \quad (5)$$

$$\partial T_{xy} / \partial x + \partial T_{yy} / \partial y + \lambda \rho v = 0 \quad (6)$$

where ρ is the density of the material, λ is unknown eigenvalue.

Substitution of (2) and (1) into (5), (6) gives an elliptic system of partial differential equations of the second order for unknown functions of displacements U and V .

USING ANSYS TO SOLVE THE PROBLEM (part 1)

Input file for modal analysis in Ansys is St2LM_1.txt.

Text output for some results is redirected to a file named Mod_ANS_1.rez using /OUTPUT command. This file will be created in a working directory of Ansys. *VWRITE command writes data to a file in a formatted sequence using Fortran format conventions (see comments in St2LM_1.txt for details).

USING FlexPDE TO SOLVE THE PROBLEM (part 1)

Input file for modal analysis in FlexPDE is St2LM.pde.

ANALYSIS OF RESULTS OBTAINED IN ANSYS (part 1)

The solid model of the double-T region is meshed with PLANE2 finite element which is a 6-node triangular structural element. Ansys versions 11 and higher uses newer elements. Although PLANE2 is not included in element library, it can still be used in all Ansys versions. Instead of PLANE2 one can use PLANE82 with triangular option:

```
ET,1,PLANE82      ! finite element PLANE82:  2D 8-Node Structural Solid
mshape,1         ! triangular option for elements
```

The finite element model with boundary conditions for modal analysis is shown Fig. 2. (Menu path: Plot->Elements, to view boundary conditions go to PltCtrls->Symbols->tick All applied BCs). To show different materials, go to PltCtrls->Symbols->tick Material numbers in Elem/Attrib numbering. Numbering can be shown with colors only.

```

ELEMENTS
MAT  NUM
U

```

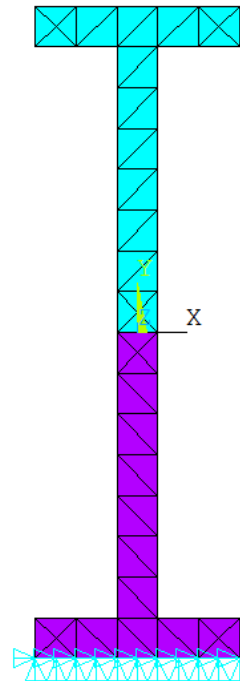

Fig. 2 Finite element model with boundary conditions for modal analysis with different materials shown

In postprocessor (General PostProc->Results Summary) it is possible to view the values of the first four natural frequencies:

***** INDEX OF DATA SETS ON RESULTS FILE *****

SET	TIME/FREQ	LOAD STEP	SUBSTEP	CUMULATIVE
1	98.218	1	1	1
2	735.42	1	2	2
3	1905.3	1	3	3
4	2619.5	1	4	4

The values of the first four natural frequencies are $f_1 = 98.2$ (Hz); $f_2 = 735.4$ (Hz); $f_3 = 1905.3$ (Hz); $f_4 = 2619.5$ (Hz).

Let us view the mode shapes that correspond to these frequencies. In order to plot mode shape (deformed shape) for each frequency value, it is necessary to read results set for this frequency (General PostProc->Read Results->By Pick). Note that the mode shapes are described by the displacement vectors, they are displayed up to a sign.

As it can be seen from Fig. 3, the first three mode shapes are flexural vibrations, and the mode shape at the fourth natural frequency is vibration of tension and compression.

DISPLACEMENT
STEP=1
SUB =1
FREQ=98.2176
DMX =.209731

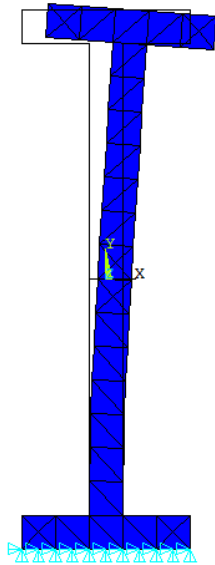

DISPLACEMENT
STEP=1
SUB =2
FREQ=735.417
DMX =.199801

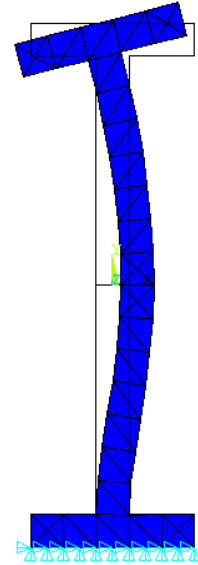

DISPLACEMENT
STEP=1
SUB =3
FREQ=1905.32
DMX =.267177

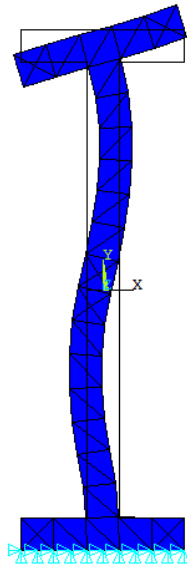

DISPLACEMENT
STEP=1
SUB =4
FREQ=2619.51
DMX =.190341

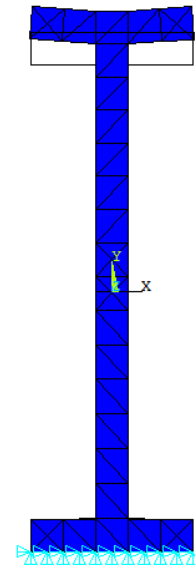

Fig. 3 Mode shapes (ANSYS)

ANALYSIS OF RESULTS OBTAINED IN FLEXPDE (part 1)

From FlexPDE calculations the values of the first four natural frequencies are: $f_1 = 98.17$ (Hz); $f_2 = 735$ (Hz); $f_3 = 1902.28$ (Hz); $f_4 = 2616.62$ (Hz).

The resulting plots display mode shapes at these frequencies (Fig. 4). If we compare results obtained in Ansys and FlexPDE, we can see that the mode shapes at the same frequencies differ only in sign. The first three mode shapes obtained in FlexPDE are flexural vibrations, and the mode shape at the fourth natural frequency is vibration of tension and compression.

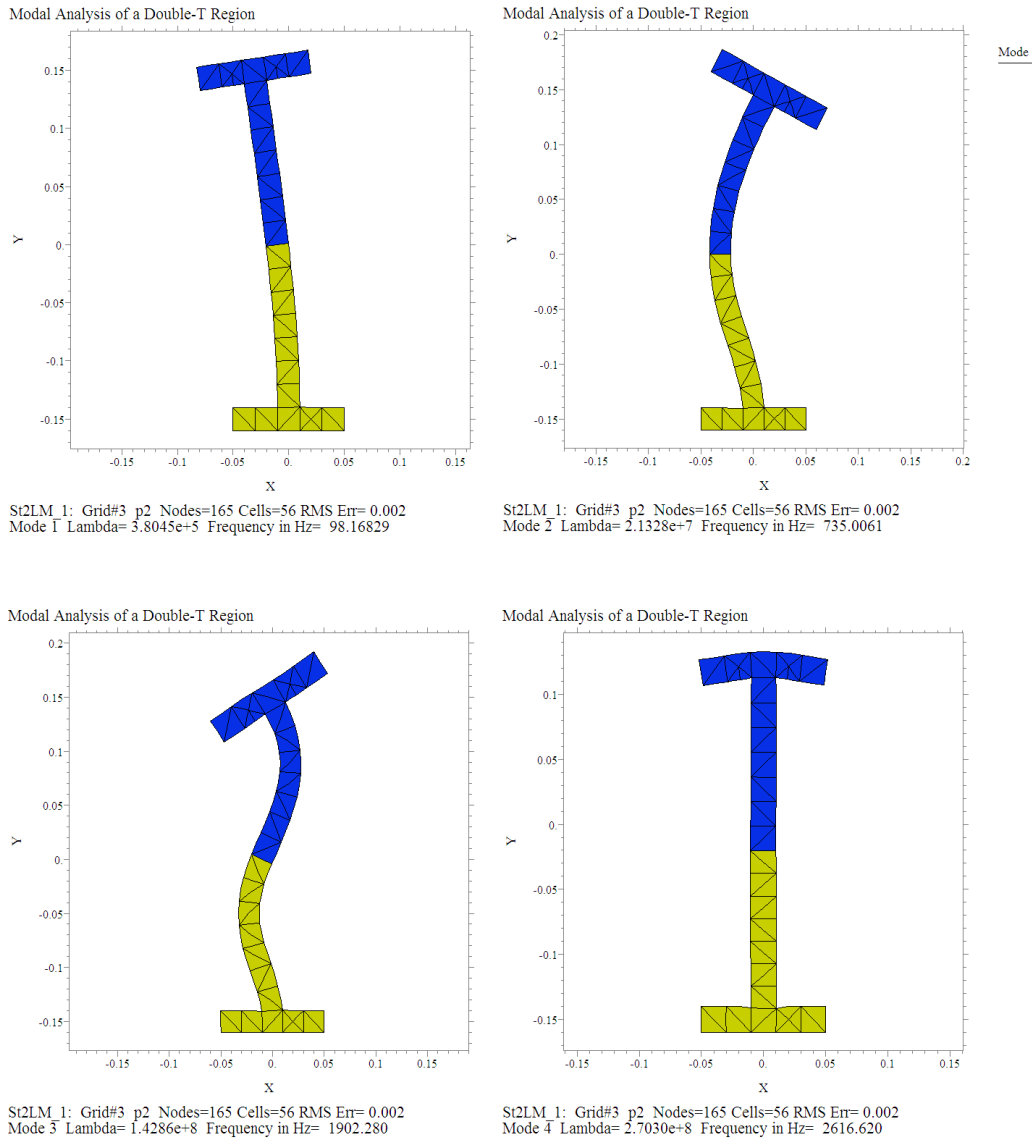

Fig. 4 Mode shapes (FlexPDE)

Part 2. Calculation of steady-state oscillations for a compound elastic plate

Problem statement

Let us consider the same plate in a shape of double T-region. The upper part of the plate is made of steel with the Young's modulus $E=2 \cdot 10^{11}$ (N/m²), Poisson's ratio $\nu=0,29$ and density $\rho=7.8 \cdot 10^3$ (kg/m³). The lower part of the plate is made of copper with the Young's modulus $E=1.2 \cdot 10^{11}$ (N/m²), Poisson's ratio $\nu=0,33$ and density $\rho=8.9 \cdot 10^3$ (kg/m³). Both parts have the shape of T-letter (Fig. 1). The dimensions are $l=0.05$ (m); $b=0.16$ (m), $h=0.02$ (m). Bottom boundary of the plate is rigidly fixed.

The objective is to perform harmonic analysis of steady-state oscillations for the given frequency interval and to plot a graph of an amplitude-frequency response. The load factors should be set in such way that they excite the natural mode shapes we have obtained in modal analysis.

Let us set the force load in the top right and left corners of the double-T region $(-l, b)$ and (l, b) : $\underline{f}_1 = \{f_0, f_0\}$, $\underline{f}_2 = \{-f_0, -f_0\}$, where $f_0 = 1000$ N (Fig. 5).

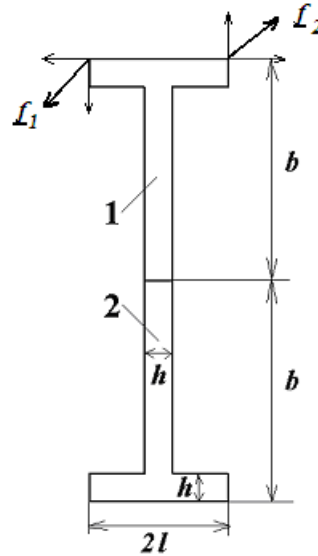

Fig. 5 Scheme of a double-T region with applied load.

Harmonic analysis is used to solve the motion equation in the case of steady-state oscillations. In the formulation of the problem of steady-state oscillations complex variables are used. The displacement vector, vectors of external forces, strains and stresses change harmonically $\underline{u} = \underline{u}_0 e^{i\omega t}$, where $\omega = 2\pi F$ is the cyclic frequency, F is the frequency.

The harmonic analysis can be performed with account for damping. The parameters of damping are calculated on the base of the frequency interval (or natural frequencies on this interval) and quality factor of the material Q . We will use the following formulae to calculate the damping coefficients on the frequency interval $[f_b, f_e]$:

$$\alpha = \frac{2\pi f_b f_e}{(f_b + f_e)Q}, \quad \beta = \frac{1}{2\pi(f_b + f_e)Q}.$$

The aim of the simulation will be to plot a graph of amplitude-frequency response and determine resonance frequencies, plot pictures of deformed shape on resonance frequencies and compare them to the corresponding mode shapes.

USING ANSYS TO SOLVE THE PROBLEM (part 2)

Input file for harmonic analysis in Ansys is S12LH_AFC_1.txt. This file uses the database from part 1 and resumes solid and finite element model and boundary conditions from modal analysis.

The frequency interval for harmonic analysis is from 50 to 900 Hz. This interval contains the first two natural frequencies. The number of calculated frequencies for this interval can be set to 250. This number can be increased to improve the accuracy of the calculations.

Text output for some results is redirected to a file named Harm1.rez using /OUTPUT command. This file will be created in a working directory of Ansys. *VWRITE command writes data to a file in a formatted sequence using Fortran format conventions.

In time-history postprocessor /POST26 it is possible to review the results in specific node for the whole frequency interval. The default first variable is TIME which is frequency for harmonic analysis. This is the variable for x-axes. The variable for y-axes is defined by NSOL command that specifies nodal data to be stored from the results file. The graph of the amplitude-frequency response is plotted by /PLVAR command.

USING FlexPDE TO SOLVE THE PROBLEM (part 2)

Input file for harmonic analysis in FlexPDE is St2LH_AFC.pde. The frequency interval is not defined in FlexPDE, instead, it is necessary to run the program several times for several frequency values. In order to obtain deformed shapes at resonance frequencies, run the program for each natural frequency value.

ANALYSIS OF RESULTS OBTAINED IN ANSYS (part 2)

The finite element model of a double-T region with boundary conditions for harmonic analysis is shown Fig. 6. (Menu path: Plot->Elements, to view boundary conditions go to PltCtrls->Symbols->tick All applied BCs)

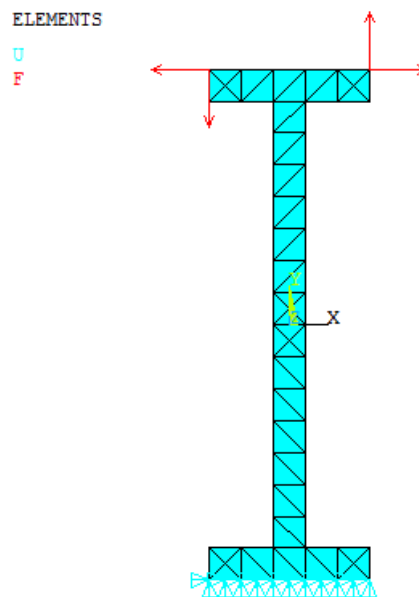

Fig. 6 Finite element model with boundary conditions for harmonic analysis

The graph of the amplitude-frequency is plotted in /POST26. The program plots the graph of the displacement u_y versus frequency (Fig. 7) for the top right corner of the double-T region with coordinates (l, b) .

POST26
 AMPLITUDE
 UY

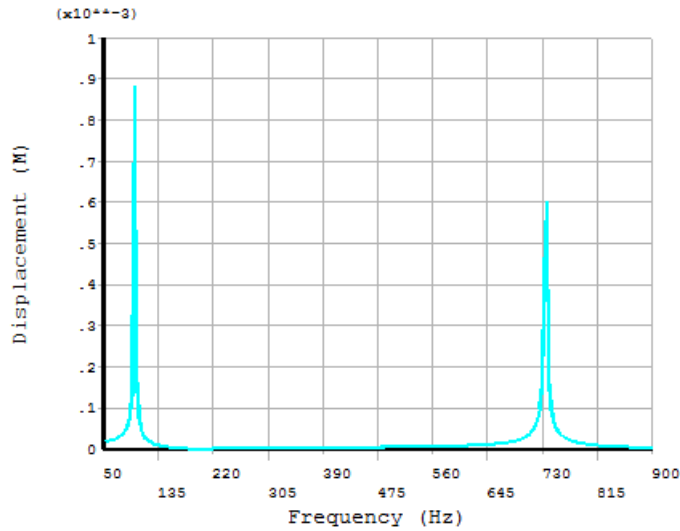

Fig. 7 Amplitude-frequency response for node (*l, b*)

From the graph we can estimate the values of the resonance frequencies. The listing of the data for this graph allows obtaining more precise values of the resonance frequencies. Menu path: TimeHist PostPro->Variable Viewer, choose variable UY, press List Data.

***** ANSYS POST26 VARIABLE LISTING *****

FREQ	20 UY	
	AMPLITUDE	PHASE
53.400	0.192111E-04	-0.366623E-01
56.800	0.201293E-04	-0.415987E-01
60.200	0.212289E-04	-0.474073E-01
63.600	0.225622E-04	-0.543564E-01
67.000	0.242043E-04	-0.628316E-01
70.400	0.262671E-04	-0.734075E-01
73.800	0.289249E-04	-0.869796E-01
77.200	0.324650E-04	-0.105024
80.600	0.373967E-04	-0.130159
84.000	0.447163E-04	-0.167510
87.400	0.566731E-04	-0.228648
90.800	0.796403E-04	-0.346371
94.200	0.141561E-03	-0.664503
97.600	0.883173E-03	-4.48547
101.00	0.188938E-03	-178.962
104.40	0.816375E-04	-179.513
107.80	0.505037E-04	-179.673
111.20	0.356966E-04	-179.748
114.60	0.270504E-04	-179.791

FREQ	20 UY	
	AMPLITUDE	PHASE
699.40	0.256776E-04	-0.553062
702.80	0.281820E-04	-0.613947
706.20	0.312687E-04	-0.689105
709.60	0.351675E-04	-0.784179
713.00	0.402479E-04	-0.908233
716.40	0.471431E-04	-1.07681
719.80	0.570376E-04	-1.31898
723.20	0.724321E-04	-1.69614
726.60	0.996742E-04	-2.36424
730.00	0.160950E-03	-3.86911
733.40	0.423414E-03	-10.3615
736.80	0.602052E-03	-164.979
740.20	0.178516E-03	-175.532
743.60	0.103845E-03	-177.367
747.00	0.729001E-04	-178.126
750.40	0.559803E-04	-178.540
753.80	0.453134E-04	-178.801
757.20	0.379738E-04	-178.981
760.60	0.326147E-04	-179.111

From the variable listing it can be seen that the largest values of the y-displacement amplitude are at the resonance frequencies $f_{r1} = 97.6$ (Hz) and $f_{r2} = 736.8$ (Hz). Note that the values of the resonance frequencies are very close to the values of the natural frequencies $f_1 = 98.2$ (Hz) and $f_2 = 735.4$ (Hz).

In command mode the value of local extrema on the graph can be determined by **GET** command. Here we need to find maximal extreme value and frequency corresponding to this value.

! Getting time/frequency value corresponding to local maximum
! *GET,PAR_NAME,VARI,VAR_NUM,EXTREM,TMAX

! Getting value of local maximum
! *GET,PAR_NAME,VARI,VAR_NUM,EXTREM,VMAX

! VAR_NUM is variable number (by default variable TIME is on x-axis and has number one)

!PAR_NAME is user name for variable on y-axis
! VARI, EXTREM, TMAX, VMAX are special labels for GET command

For example, after the set of commands for the graph plot

```
/POST26
/XRANG,FBEG,FEND
/AXLAB,X,Frequency (Hz)
/AXLAB,Y,Displacement (M)
NSOL,2,N_RES2,UY
PLVAR,2
```

The user can add:

***GET,FRES,VARI,2,EXTREM,TMAX ! Get resonance frequency**

***GET,DISP_MAX,VARI,2,EXTREM,VMAX ! Get displacement value at resonance frequency**

For the previous two commands it is recommended to set a frequency interval for the local maximum search.

!Time/frequency interval
TIMERANGE,T_MIN,T_MAX
! T_MIN, T_MAX define the interval

In order to plot the deformed shapes at the resonance frequencies, it is necessary to first read the results from the set for the corresponding frequency (General PostProc->Read Results->By Pick). There are two result sets for each frequency value, they correspond to the real and imaginary parts of the displacement vector.

Fig. 8 shows the deformed shapes for the real and imaginary parts of the displacement vector at the resonance frequency $f_{r1} = 97.6$ (Hz). It can be seen that these deformed shapes coincide with each other up to a sign. The deformed shape for the imaginary part of the displacement vector coincide with the mode shape at the first natural frequency $f_1 = 98.17$ (Hz).

Fig. 9 shows the deformed shapes for the real and imaginary parts of the displacement vector at the resonance frequency $f_{r2} = 736.8$ (Hz). It can be seen that these deformed shapes coincide with each other, and also coincide up to a sign with the mode shape at the second natural frequency $f_2 = 735$ (Hz).

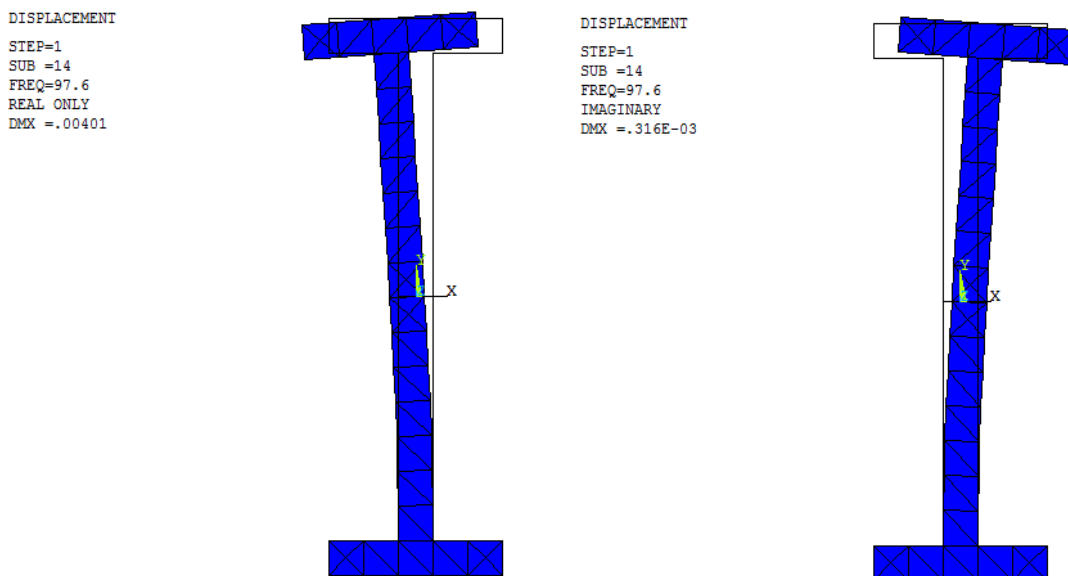
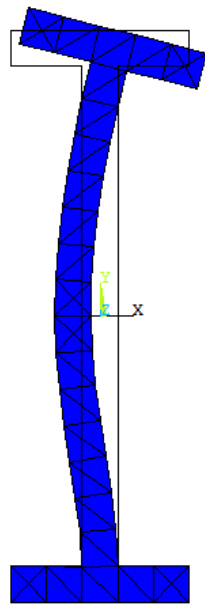

Fig. 8 Deformed shapes at the first resonance frequency of 97.6 Hz (ANSYS)

DISPLACEMENT
 STEP=1
 SUB =202
 FREQ=736.8
 REAL ONLY
 DMX =.734E-03



DISPLACEMENT
 STEP=1
 SUB =202
 FREQ=736.8
 IMAGINARY
 DMX =.197E-03

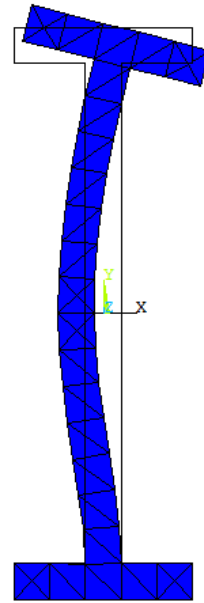

Fig. 9 Deformed shapes at the second resonance frequency of 736.8 (ANSYS)

ANALYSIS OF RESULTS OBTAINED IN FlexPDE (part 2)

Fig. 10 shows the deformed shapes for the real and imaginary parts of the displacement vector at the frequency $f_1 = 98.17$ (Hz). It can be seen that these deformed shapes coincide with each other, and also coincide with the mode shape at the first natural frequency.

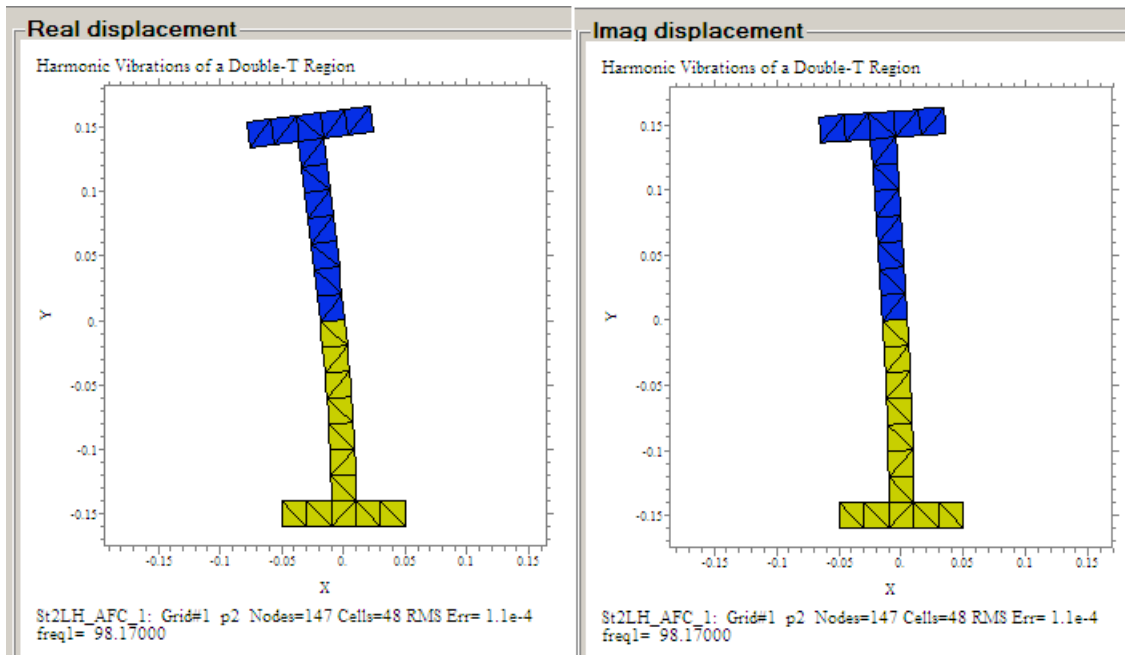

Fig. 10 Deformed shapes at the first resonance frequency (FlexPDE)

Fig. 11 shows the deformed shapes for the real and imaginary parts of the displacement vector at the frequency $f_2 = 735$ (Hz). It can be seen that the deformed shape for the real part of the displacement vector coincides up to a sign with the mode shape at the second natural frequency.

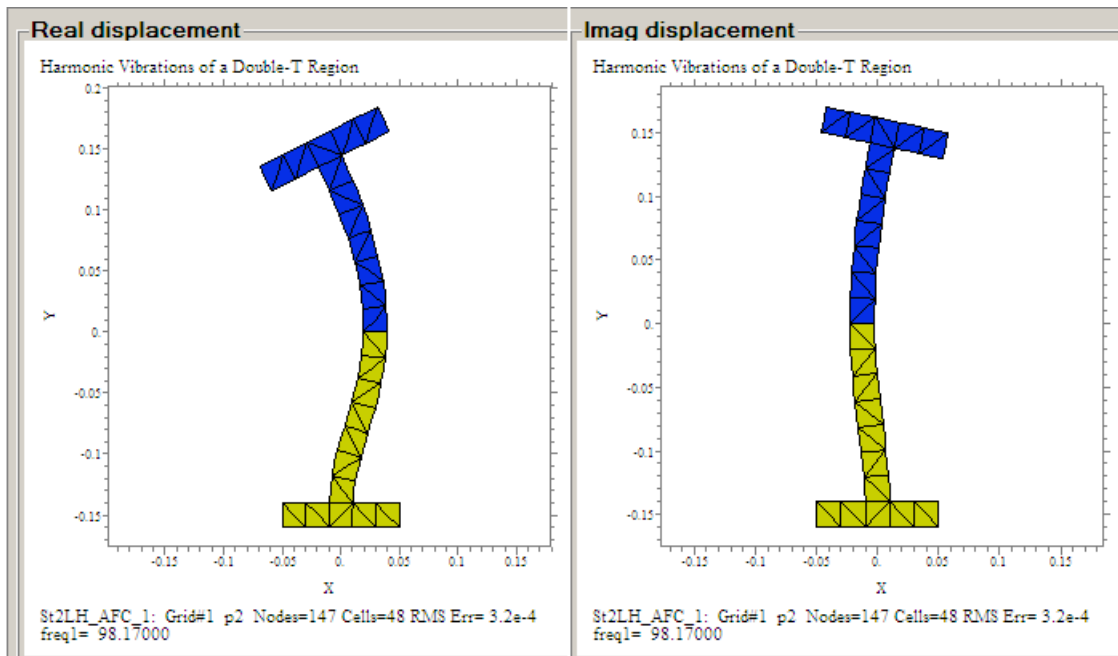

Fig. 11 Deformed shapes at the second resonance frequency (FlexPDE)