

DE0-CV Board

<i>SCHEMATIC</i>	<i>CONTENT</i>	<i>PAGE</i>
Cover	Cover Page	01
Block Diagram	Block Diagram	02
FPGA	FPGA IO, Clock, Configuration and Power	03 ~ 09
Memory	SDRAM, SD Card	10
Video	VGA	11
User Interface	GPIO_0,GPIO_1 - two 2x20 Header	12~13
User Interface	LED and 7'Segment	14
User Interface	PS2 and Switch and Key	15
Power	Power	16

SDRAM

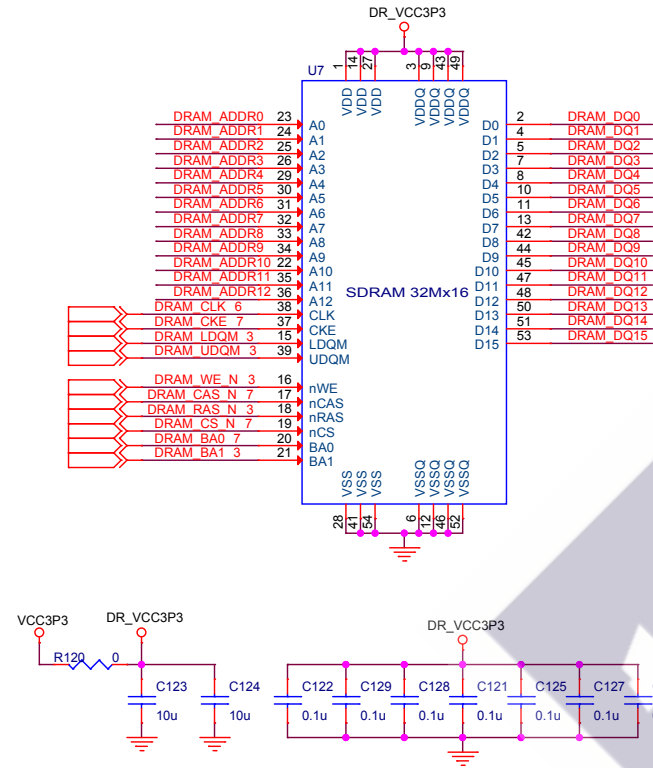
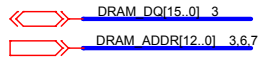

Micro SD Card

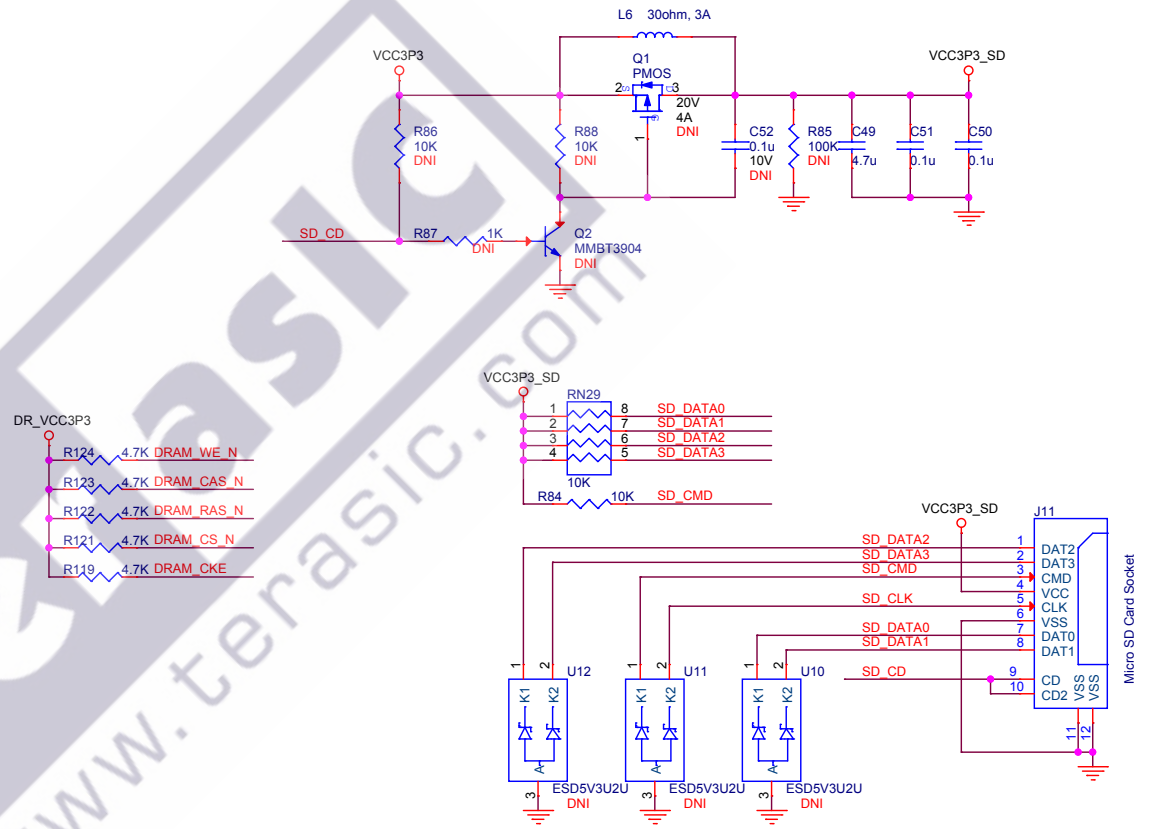
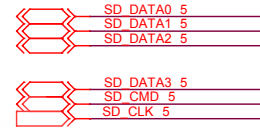

VGA

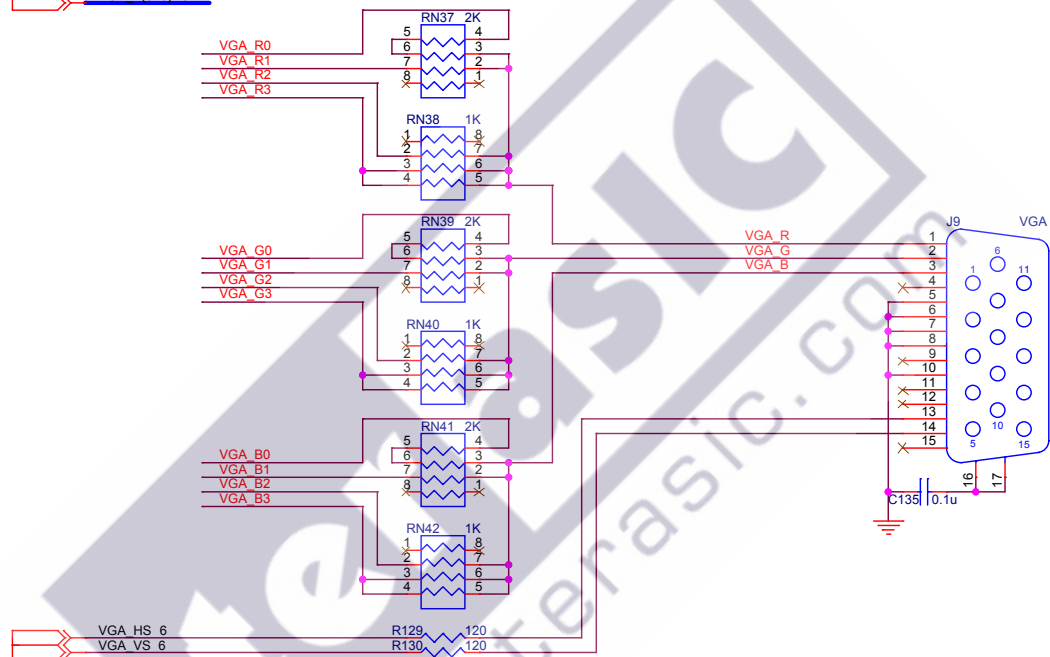
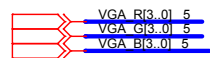

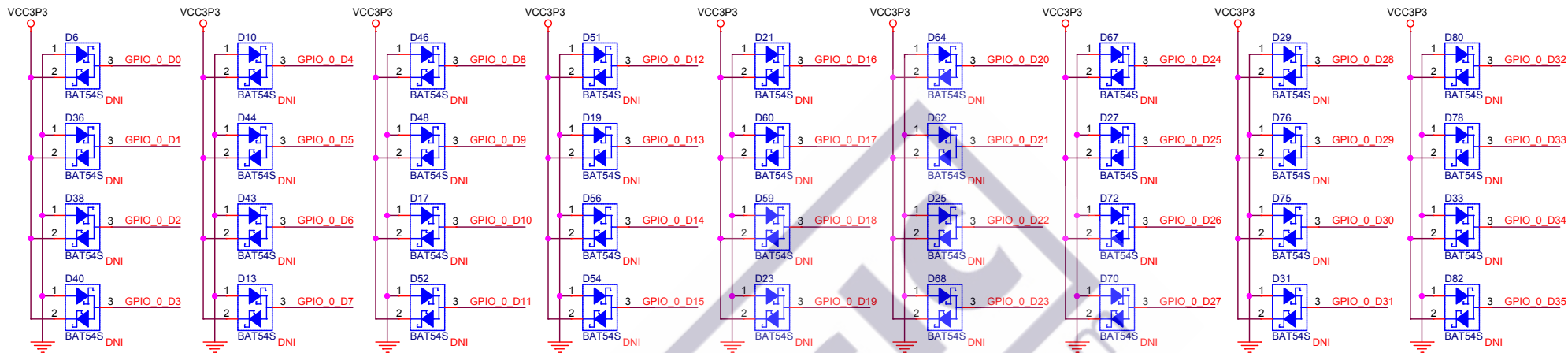

GPIO 0

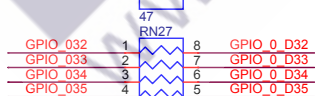
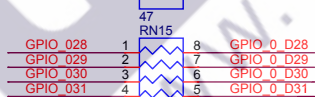
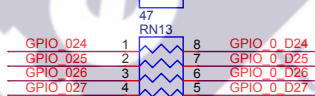
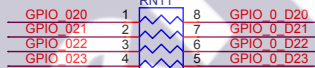
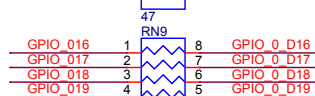
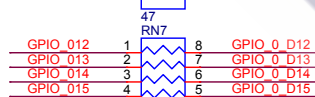
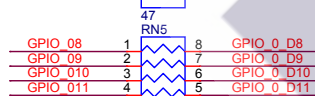
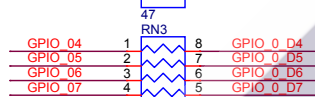
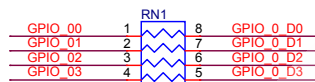

GPIO 0

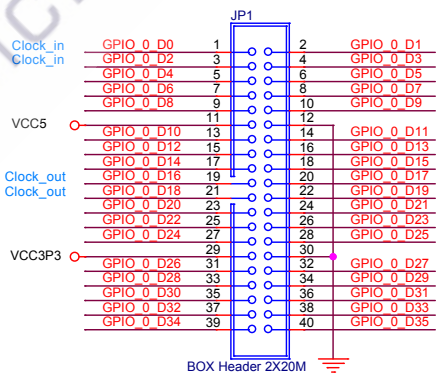

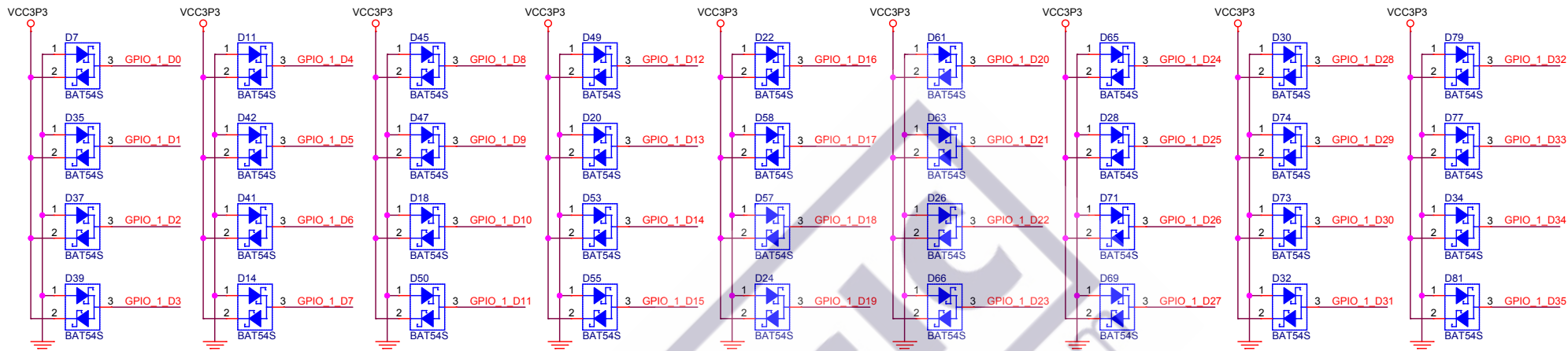

GPIO 1

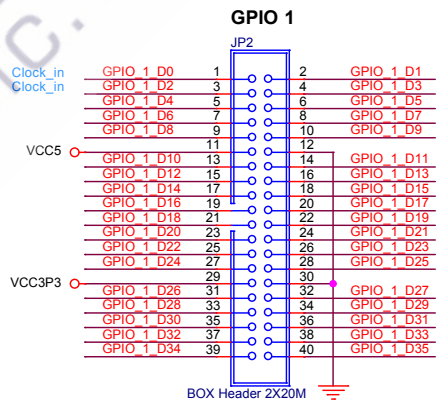
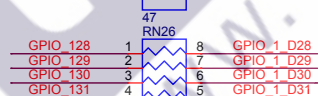
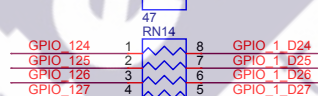
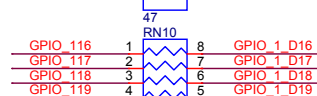
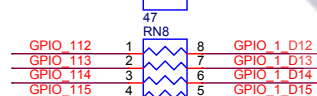
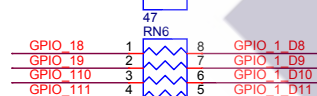
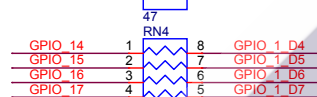
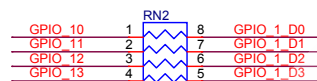

7-Segment

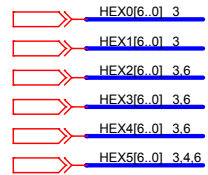

LED

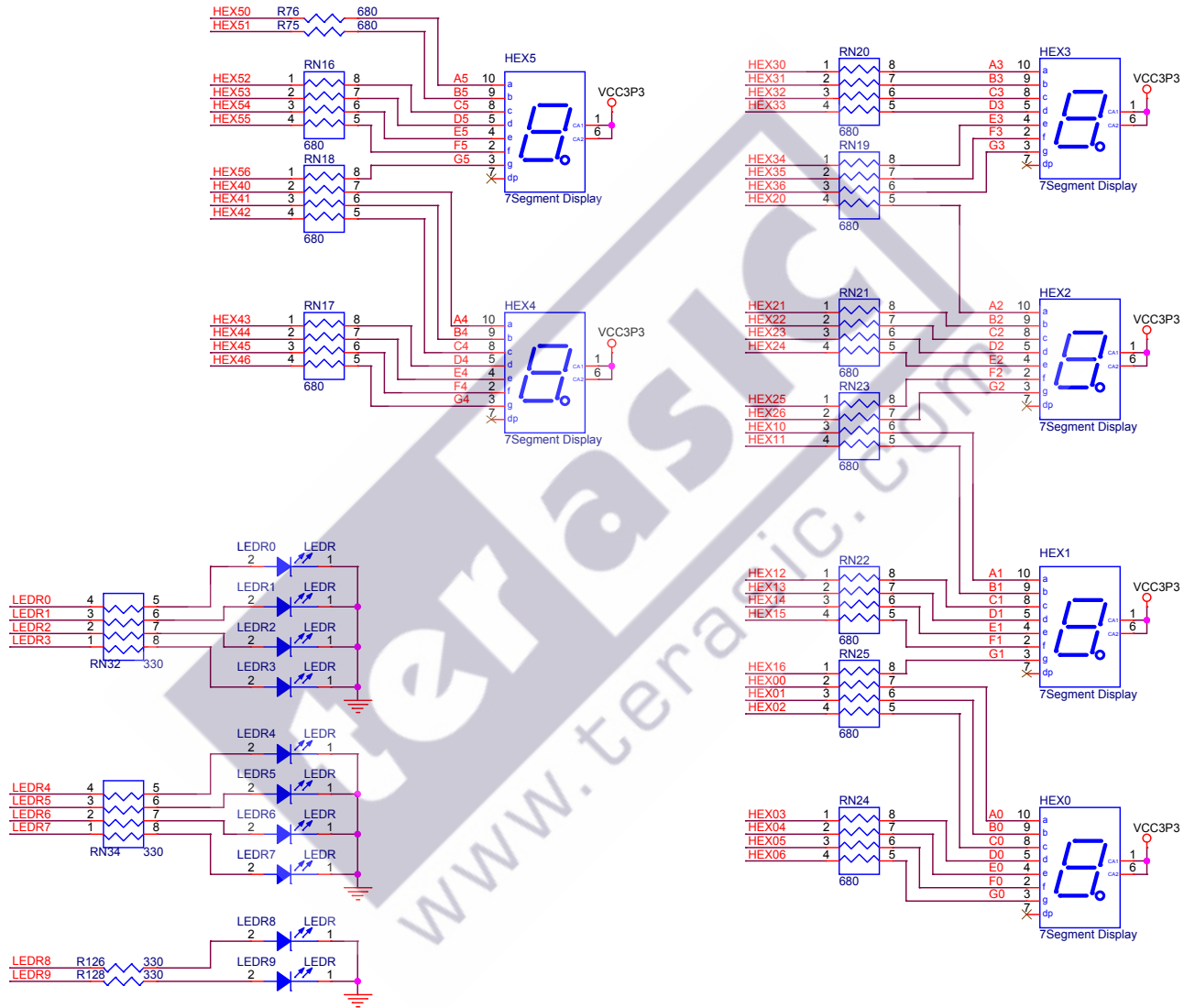

PS/2

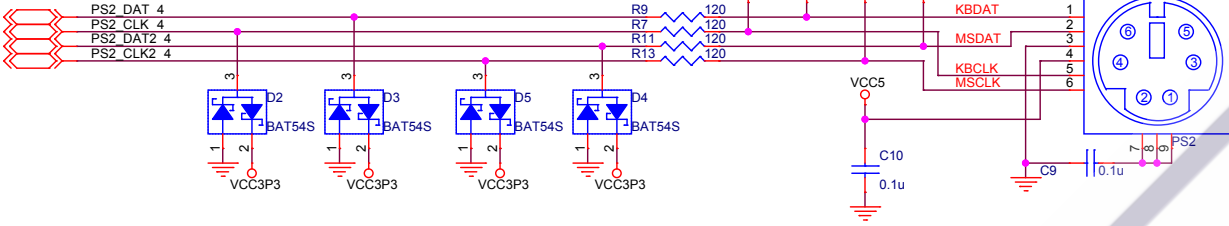

Switch
SW19_01_3

BUTTON
KEY13_01_7

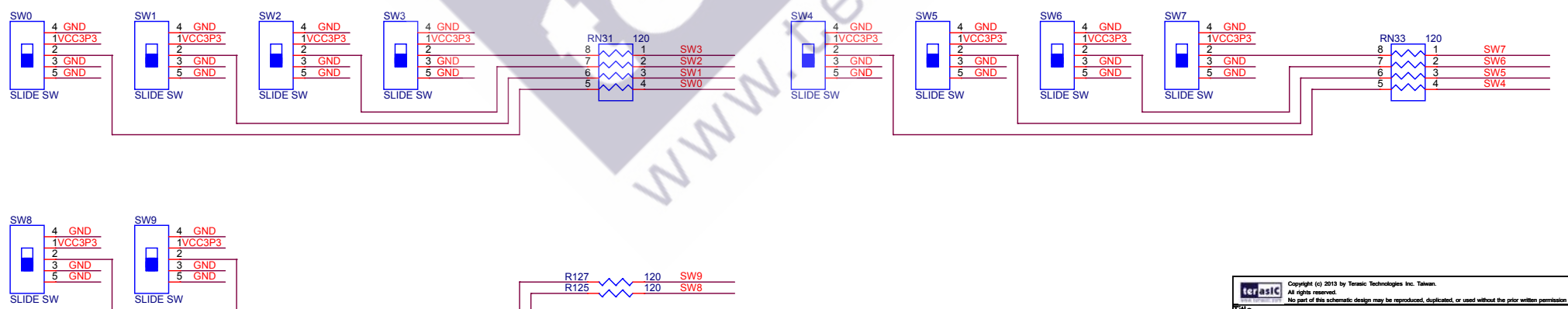
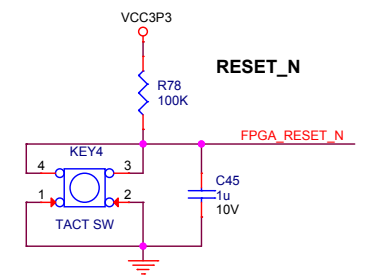
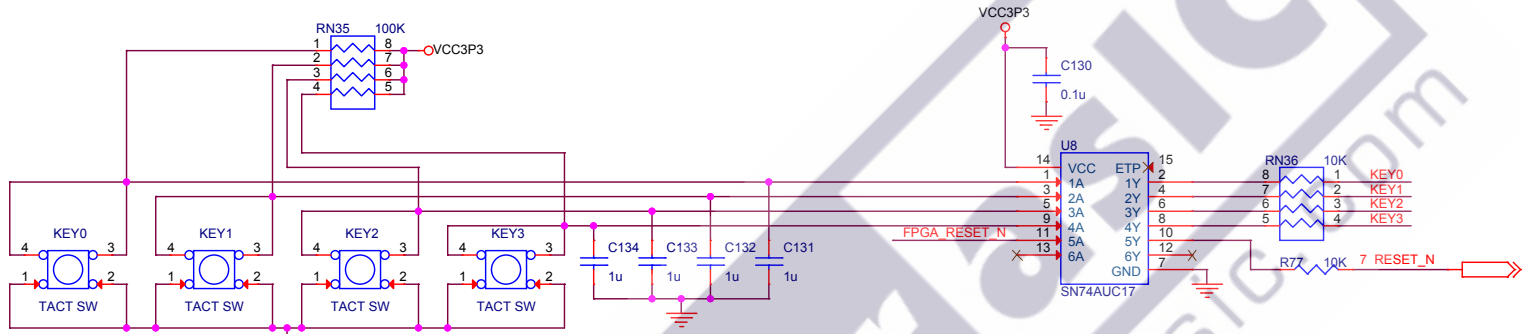

Copyright (c) 2013 by Terasic Technologies Inc. Taiwan. All rights reserved. No part of this schematic design may be reproduced, duplicated, or used without the prior written permission of Terasic.		
Title DE0-CV Board		
Size B	Document Number PS2, SW, KEY	Rev C
Date: Friday, July 03, 2015	Sheet 15 of 17	

DC 5V Power Input

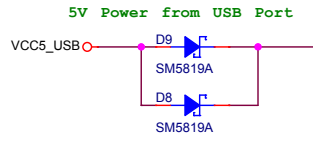
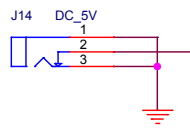

Overvoltage Protection
Threshold Voltage : 5.45V

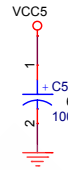

2.5V / 1A

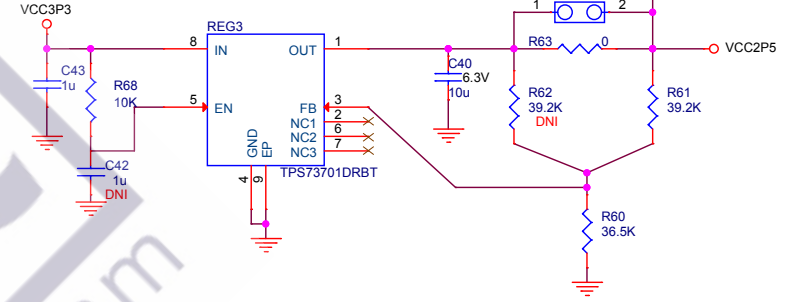

1.1V / 3A
Ramp Time = 0.8 msec
Switching Frequency : 2.4MHz

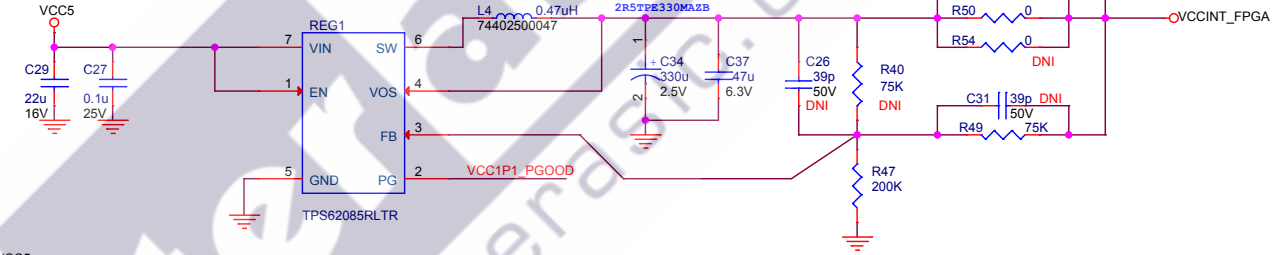

3.3V / 3A
Ramp Time = 0.8 msec
Switching Frequency : 2.4MHz

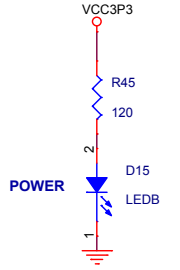
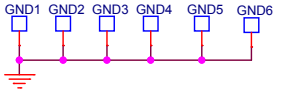
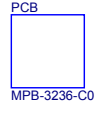
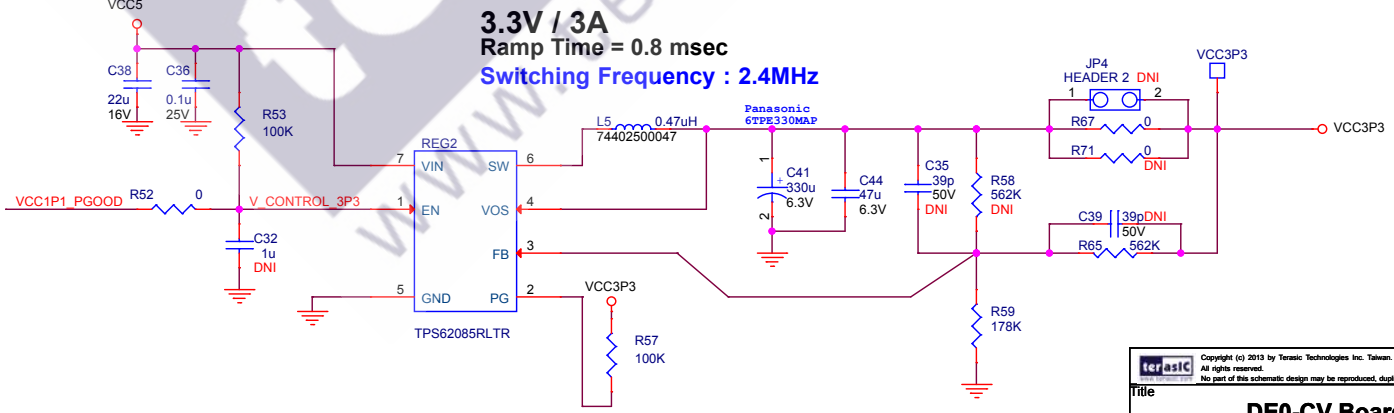

Copyright (c) 2013 by Terasic Technologies Inc. Taiwan. All rights reserved. No part of this schematic design may be reproduced, duplicated, or used without the prior written permission of Terasic.		
Title		
DE0-CV Board		
Size	Document Number	Rev
B	Power - 1.1V, 2.5V, 3.3V, 5V	C
Date:	Friday, July 03, 2015	Sheet 16 of 17

